

Mechanisms regulating prostaglandin H₂ synthase-2 mRNA level in the amnion and chorion during pregnancy

Renée F Johnson^{2,3}, Carolyn M Mitchell³, Warwick B Giles^{1,2,3}, Andrew Bisits^{1,2,3} and Tamas Zakar^{1,2,3}

¹Division of Obstetrics and Gynaecology, John Hunter Hospital, Newcastle, New South Wales, Australia

²Discipline of Reproductive Medicine, University of Newcastle, Newcastle, New South Wales, Australia

³Mother's and Babies Research Centre, Hunter Medical Research Institute, Newcastle, New South Wales, Australia

(Requests for offprints should be addressed to T Zakar; Division of Obstetrics and Gynaecology, Mothers and Babies Research Centre, John Hunter Hospital, Locked Bag 1, Hunter Region Mail Centre, Newcastle, N.S.W. 2310 Australia; Email: tzakar@mail.newcastle.edu.au)

Abstract

Increasing prostaglandin H₂ synthase (PGHS)-2 expression in the fetal membranes is implicated in the production of prostaglandins (PGs) that stimulate labour. We have determined the activity of the PGHS-2 gene in the amnion and chorion throughout gestation and defined the contribution of transcriptional and post-transcriptional mechanisms to the increase of PGHS-2 mRNA levels. We also measured PGHS-1 mRNA abundance to assess the participation of the two isoenzymes in fetal membrane PG-production during pregnancy. Amnion and chorion were collected from non-labouring women at 10–19 weeks (early), at 28–36 weeks (preterm) and at term (37–41 weeks). We determined PGHS-1 and -2 mRNA abundance and assessed PGHS-2 gene activity by measuring PGHS-2 heterogeneous nuclear RNA levels using real-time RT-PCR. PGHS-2 gene activity and mRNA

levels were up-regulated in both tissues with advancing gestation. Path analysis demonstrated that the PGHS-2 mRNA up-regulation involved both transcriptional and post-transcriptional components. PGHS-2 mRNA abundance increased 9–11 fold between the early (10–19 weeks) and preterm (28–36 weeks) groups and remained high at term. The underlying mechanism was predominantly transcriptional in the amnion and post-transcriptional in the chorion. PGHS-1 mRNA expression precipitously decreased between early gestation and term. Thus, PGHS-2 mRNA abundance is up-regulated well in advance of term and is not a trigger for labour. There is a switch in PGHS mRNA expression during pregnancy with PGHS-1 dominating in the early period and PGHS-2 dominating at term.

Journal of Endocrinology (2006) **188**, 603–610

Introduction

Prostaglandins (PGs) produced by intrauterine tissues play important roles throughout gestation. In early human pregnancy, PGs are involved in implantation, pregnancy recognition and the immune tolerance of the fetus (Lala 1989, Norwitz *et al.* 2001), while towards term, PGs are critical for the initiation and maintenance of labour (Challis *et al.* 2000). The fetal membranes (amnion and chorion laeve) are major intrauterine sources of PGE₂ and PGF_{2α}. Both membranes express the PG-biosynthetic enzymes including the two prostaglandin H₂ synthases, PGHS-1 and -2 (Trautman *et al.* 1996). The PGHS isoenzymes have key importance in the regulation of PG synthesis, because they catalyse the committing and rate-limiting step of the biosynthetic pathway (Smith *et al.* 2000).

PGHS-1 and -2 are encoded by separate genes; PGHS-1 is constitutively expressed and developmentally regulated in many tissues, while PGHS-2 expression is

induced and modulated by a variety of agonists such as growth factors, glucocorticoids, cytokines and endotoxin (Smith *et al.* 2000). The disparate regulation of the two isoenzymes suggests that the PGs produced by PGHS-1 and -2 may have distinct physiological functions.

PGHS-2 mRNA levels increase in the fetal membranes with advancing pregnancy (Mijovic *et al.* 1998, 1999, Slater *et al.* 1999), and an additional increase occurs during labour (Hirst *et al.* 1995, Slater *et al.* 1995, 1998, Mijovic *et al.* 1997). Furthermore, PGHS-2 mRNA abundance correlates with PGHS enzyme activity both in the amnion and in the chorion laeve (Hirst *et al.* 1995, Mijovic *et al.* 1998), implicating PGHS-2 in the production of PGs that stimulate labour. PGHS-1 mRNA expression is generally low in both tissues (Slater *et al.* 1994), but increasing PGHS-1 mRNA abundance has been reported in the amnion and chorion at late gestation (Mijovic *et al.* 1998, 1999). Others detected no change in PGHS-1 levels at term as opposed to earlier gestational ages (Slater *et al.* 1999).

There is consensus, however, that PGHS-1 levels remain unchanged in the amnion and chorion during labour (Freed *et al.* 1995, Hirst *et al.* 1995, Mijovic *et al.* 1997, Sadovsky *et al.* 2000).

In previous studies, we have explored the mechanisms that control PGHS-2 mRNA expression in the fetal membranes at term before and after labour. We have found that PGHS-2 gene activity significantly determines PGHS-2 mRNA abundance (Johnson *et al.* 2002, 2003) in term amnion and chorion laeve. PGHS-2 gene activity, however, did not change in the two tissues during labour, suggesting that post-transcriptional mechanism(s) were involved in the labour-associated increase of PGHS-2 mRNA expression. In addition, PGHS-2 mRNA degradation rates were low and comparable to a constitutively expressed mRNA in both fetal membranes. Based on these results, we have concluded that PGHS-2 mRNA is generated at a steady rate in term fetal membranes and that the resulting stable PGHS-2 mRNA accumulates in the tissues up-regulating enzyme expression during labour.

In the present investigation, we have examined the mechanisms that control PGHS-2 mRNA levels in the amnion and the chorion during pregnancy. We have collected fetal membranes from non-labouring women between early pregnancy and term and measured PGHS-2 gene activity and mRNA abundance in the amnion and the chorion laeve. We have defined the gestational period when PGHS-2 gene activity and mRNA levels are up-regulated and determined the contribution of transcriptional or post-transcriptional mechanisms to the increase of PGHS-2 mRNA expression. In addition, we have measured PGHS-1 mRNA levels and assessed the participation of the PGHS-1 isoform in fetal membrane PG production throughout pregnancy.

Materials and Methods

Patients and tissues

Placentas with attached fetal membranes were obtained at the John Hunter Hospital, Newcastle NSW, Australia, from 47 singleton pregnancies within 30 min of birth. All tissues were delivered in the absence of labour by elective Caesarean section either at term (TNL, $n=27$) or preterm not-in-labour (PNL, $n=20$). Women in the TNL group were delivered between 37 and 41 weeks of gestation, while women in the PNL group were delivered between 28 and 36 weeks of pregnancy. The indications of preterm Caesarean deliveries were placenta praevia (4 cases), diabetes (4 cases), pregnancy-induced hypertension (5 cases) and maternal and fetal complications (7 cases). These conditions had no influence on the parameters measured in this study (tested by Kruskal–Wallis ANOVA) therefore the PNL patients were treated as a homogeneous group in the context of the present investigation. A further group, early gestation (ENL) of 19 tissues were obtained from

women undergoing early elective termination, between 10 and 19 weeks of gestation, at a private day-surgery. Women presenting with a gestational age greater than 16 weeks were treated with Cytotec 90 min prior to the termination procedure. Termination of pregnancy was through a vacuum suction procedure. Samples were collected in sterile containers and transferred to the laboratory on ice for the isolation of fetal membranes.

Women receiving treatment with non-steroidal anti-inflammatory drugs (NSAIDs) within three days before delivery, or with a history of infection, histological chorioamnionitis, or severe asthma were excluded from the study. Informed voluntary written consent was obtained from all participating women. The collection and use of these tissues had been approved by the Hunter Area Health Service and the University of Newcastle Human Ethics Committees.

Tissue collection and preparation of total RNA

The amnion membrane was separated from chorio-decidua by blunt dissection. The chorion laeve was isolated by removing the attached decidua by sharp dissection as described (Johnson *et al.* 2003, 2004). This validated dissection technique removes most ($\approx 85\%$) of the decidua and results in a uniform preparation as determined by phase-contrast microscopy (Mitchell & Powell 1984, Powell *et al.* 1986, Mijovic *et al.* 1998). The isolated amnion and chorion laeve were blotted to remove blood, snap frozen in liquid nitrogen and stored at -80°C .

Total RNA was extracted from 1 g of crushed frozen amnion or chorion laeve using TRIzol reagent (Invitrogen, Mt Waverley, Australia) according to the manufacturer's protocol. Following extraction, the RNA was purified and DNase-treated using Qiagen Mini-Spin columns and the Qiagen RNase-free DNase kit (Qiagen) according to the manufacturer's protocol. The integrity of purified RNA was confirmed by visualisation of the 18S and 28S rRNAs following agarose gel electrophoresis.

Quantitative real-time RT-PCR

Three micrograms of purified total RNA was reverse transcribed using the Invitrogen First Strand Synthesis Kit for RT-PCR with random hexamers as primers, according to the manufacturer's instructions. Primers for the quantitative real-time PCR reaction were designed using the Primer Express v1.0 computer software (PE Biosystems, Branchburg, NJ, USA). The primer sequences for PGHS-2 hnRNA, PGHS-2 mRNA and β -actin mRNA were described previously (Johnson *et al.* 2002). Primers for PGHS-1 mRNA were designed to span exons 10 and 11 and amplify an 85 base pair amplicon corresponding to base positions 1386–1470 within the open reading frame (Funk *et al.* 1991). The PGHS-1 mRNA forward primer

sequence was 5'-CAATGAGTACCGCAAGAGGTTTG-3' and the reverse primer sequence was 5'-CAACTCTGCTGCCATCTCCTT-3'.

Quantification of PGHS-2 hnRNA and mRNA, PGHS-1 mRNA and β -actin mRNA was performed by quantitative real-time PCR procedures described and validated previously (Johnson *et al.* 2002, 2003). Briefly, each mRNA sequence was amplified in triplicate in 25 μ l reactions containing SYBR green PCR master mix (Applied Biosystems, Warrington, UK), cDNA corresponding to 40 ng of reverse transcribed RNA and 400 nM each of forward and reverse primers (synthesized by Invitrogen). Optimal primer concentrations and template amounts to achieve constant and equal amplification efficiency of the target and reference sequences have been determined in preliminary experiments as described (Johnson *et al.* 2002, 2003). Real-time PCR was performed using an ABI Prism 7700 Sequence Detector. Controls (no template and no reverse transcriptase) were included for each amplification reaction, and the homogeneity of the amplified products was confirmed routinely by melting curve analysis and agarose gel electrophoresis.

Data analysis

The abundance of the target sequences was calculated relative to β -actin mRNA using the formula: relative abundance = $2^{-\Delta CT}$, where ΔCT is calculated as the difference between the C_T (threshold cycle) of the test sequences and of the reference β -actin mRNA sequence. The raw data were not normally distributed, as established with the skewness-kurtosis test; therefore differences between the median relative abundance values of the patient groups were examined using the Kruskal–Wallis ANOVA followed by the non-parametric Dunn's multiple comparisons test if a significant effect was found. For parametric analyses, the data were transformed to logarithms and normal equivalent deviates (Rowe 2002) to achieve normal distributions in the data. Analysis results were equivalent using either transformation. Relationships have been determined by Robust Regression and the AMOS path analysis procedure (AMOS 5; Small Waters Corporation, Chicago, IL, USA). In all statistical tests, $P < 0.05$ was considered significant. In the path analysis, a P value well above 0.05 indicated a consistency of the data with the hypothesised paths.

Results

PGHS-2 gene activity in the fetal membranes during pregnancy and its relationship with PGHS-2 mRNA level

Fig. 1 shows PGHS-2 hnRNA relative abundance (A) and PGHS-2 mRNA relative abundance (B) in

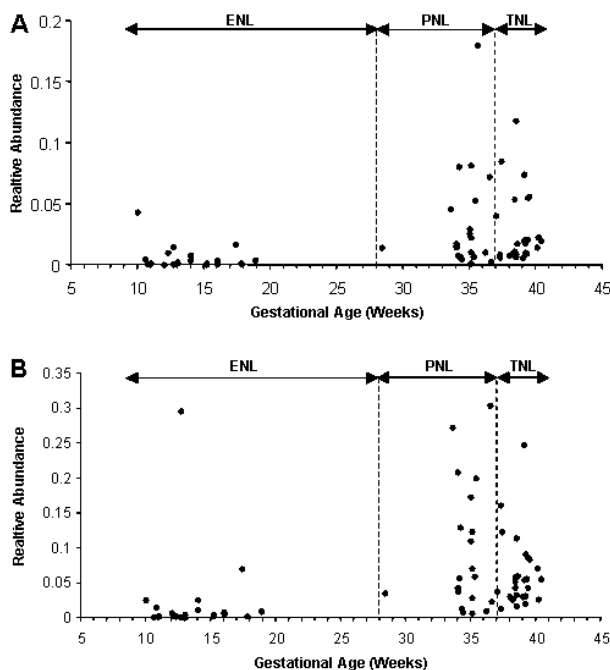

Figure 1 PGHS-2 hnRNA (A) and mRNA (B) relative abundance in the amnion during pregnancy. Tissues were obtained from non-labouring women. The arrows and broken lines indicate the gestational age groups (ENL, PNL and TNL) used in subsequent analyses.

amnion membranes collected between 10 and 41 weeks of pregnancy. PGHS-2 hnRNA and mRNA relative abundance in the chorion laeve is shown in Fig. 2 Panels A and B, respectively. Heterogeneous nuclear RNA (hnRNA) is the immediate product of gene transcription and is the un-spliced precursor of mRNA. The level of hnRNA has been proposed to serve as surrogate measure of gene transcription rate in fresh tissues (Elferink & Reiners 1996). We have validated this method for measuring PGHS-2 gene activity in human amnion and chorion laeve by showing that PGHS-2 hnRNA abundance is correlated with PGHS-2 gene transcription rate, determined by transcriptional run-on (Johnson *et al.* 2002, 2003). Subsequently, we have used PGHS-2 hnRNA relative abundance to assess the transcriptional activity of the PGHS-2 gene in term fetal membranes at labour (Johnson *et al.* 2002, 2003). Figs 1 and 2 show that PGHS-2 hnRNA and mRNA levels varied in individuals during pregnancy. An increase with gestational age is apparent by visual assessment, which was in agreement with previous reports on PGHS-2 mRNA, as indicated. For the quantitative evaluation of relationships between gestational age, PGHS-2 gene activity and PGHS-2 mRNA level, we have constructed a model, shown in Fig. 3. In the model, PGHS-2 gene activity is dependent on gestational age (Relationship A), and PGHS-2 mRNA level is dependent on PGHS-2 gene activity (Relationship B).

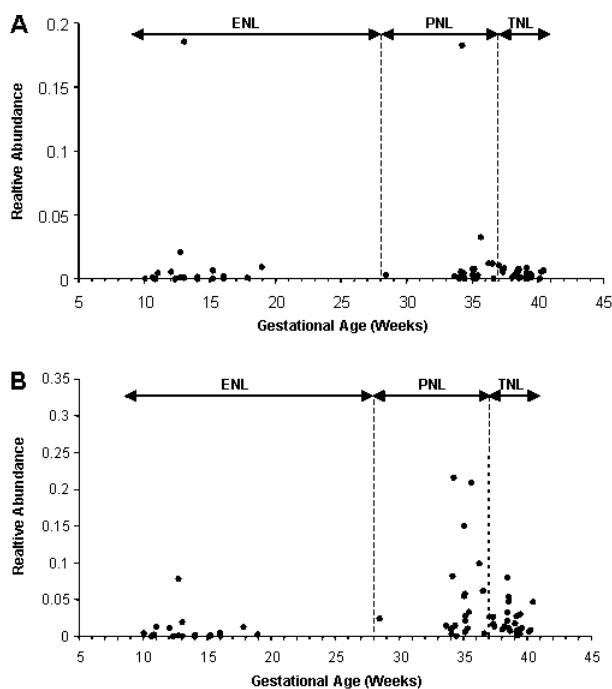

Figure 2 PGHS-2 hnRNA (A) and mRNA (B) relative abundance in the chorion laeve during pregnancy. The details are as described in Fig. 1.

In addition, PGHS-2 mRNA level is influenced by gestational age in a way that is independent of gene activity, representing post-transcriptional regulation (Relationship C). Variance not explained by these relationships are error terms (Errors -1 and -2).

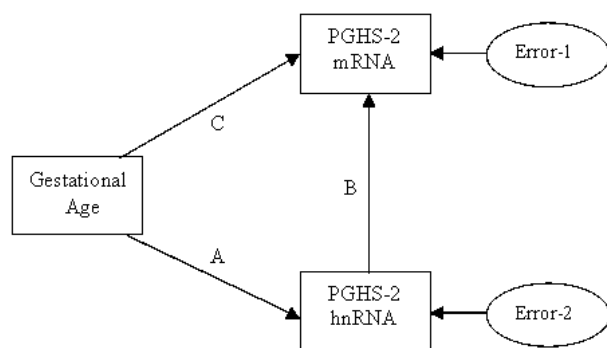

Figure 3 Model describing the network of pathways tested by path analysis (AMOS). Arrows indicate relationships as follows: A, relationship between gestational age and PGHS-2 hnRNA level (a surrogate measure of gene activity); B, relationship between PGHS-2 hnRNA and mRNA levels; C, relationship between gestational age and PGHS-2 mRNA level (independent of gene activity). Variables representing error are also included in the model.

First, we have tested Relationship A by regression analysis. Table 1 shows that gestational age significantly predicts PGHS-2 hnRNA abundance in both tissues. The regression coefficients are positive, indicating that PGHS-2 gene activity increases in both membranes with advancing pregnancy. This relationship, however, prevented the use of conventional multiple regression to examine the contribution of transcriptional and post-transcriptional mechanisms to the control of PGHS-2 mRNA level (Relationships B and C), because the corresponding independent variables, PGHS-2 hnRNA level and gestational age, were highly correlated. Therefore, we have employed path analysis (AMOS) to address this question, since this procedure allows the recognition of independent relationships in the presence of correlated independent variables. As summarised in Table 2, the data fit the model with high probability in both tissues, showing that gene activity and gestational age predict PGHS-2 mRNA abundance significantly, independently and with positive coefficients. Thus, testing by path analysis has provided statistical evidence that transcriptional and post-transcriptional mechanisms contribute to the up-regulation of PGHS-2 mRNA levels during pregnancy.

PGHS-2 gene activity and mRNA abundance in early and late pregnancy and at term

The distribution of data on Figs 1 and 2 suggests that most of the increase in PGHS-2 gene activity and mRNA levels occurs towards late gestation. To evaluate this possibility, we have divided the data into 3 groups according to gestational age. As indicated on the figures, the ENL group comprises samples from early pregnancy, the PNL group contains tissues from advanced but still preterm pregnancies and the TNL group consists of tissues obtained at term. PGHS-2 hnRNA and mRNA levels have been compared among the groups, and the results are presented in Table 3. In the amnion, PGHS-2 mRNA abundance was relatively low in ENL and increased significantly as pregnancy advanced. Specifically, the median value in the late gestation PNL group was more than 11-fold higher than in the ENL group. PGHS-2 mRNA levels did not change further with progress to TNL. The activity of the PGHS-2 gene had a similar time course; in the PNL group, the median PGHS-2 hnRNA relative abundance value was significantly higher than in the ENL group (6.8-fold increase) and no further change was detected at term.

In the chorion, PGHS-2 mRNA relative abundance was lowest in ENL group; with a significant increase in the PNL group. The increase of the median values was 9-fold. There was no further significant change as pregnancy reached term. The median levels of PGHS-2 hnRNA did not differ significantly among the three groups.

Table 1 The relationship of PGHS-2 hnRNA relative abundance¹ to gestational age² in the amnion and the chorion laeve

Robust Regression estimates	
Amnion	$n=66$; $F(1,64)=34.79$; $P>F=0.0000$ Coefficient: 0.036 (95% confidence interval: 0.024–0.048); $P< t =0.000$
Chorion laeve	$n=66$; $F(1,64)=6.63$; $P>F=0.0123$ Coefficient: 0.017 (95% confidence interval: 0.0037–0.029); $P< t =0.012$

¹Measured relative to β -actin mRNA. ²Tissues were obtained between 10 and 41 weeks of gestation. Predictor variable: gestational age in weeks; response variable: PGHS-2 hnRNA relative abundance. Analysis was performed with logarithmically transformed data.

PGHS-1 mRNA levels in the amnion and chorion laeve during pregnancy

We have also measured PGHS-1 mRNA relative abundance in the fetal membrane samples (Fig. 4). PGHS-1 mRNA was detectable in all tissues by Q-RT-PCR, and regression analysis demonstrated a gestational age-dependent decrease of PGHS-1 mRNA relative abundance in both membranes (Table 4). Expression was highest in the ENL group, dropped precipitously by late

gestation PNL and continued to decrease by TNL. In the amnion, the median PGHS-1 relative abundance fell by 90% at term, while in the chorion, the decrease was 98% compared with early gestation (Table 3).

Discussion

Several groups have examined previously the expression of PGHS in the human fetal membranes (Teixeira *et al.* 1994,

Table 2 Summary of path analysis results (AMOS) based on the model in Fig. 3¹

Amnion	Goodness of fit ² : $P=0.929$ Coefficient for Relationship B: 0.668 (S.E.M.: 0.099), $P<0.001$ Coefficient for Relationship C: 0.014 (S.E.M.: 0.006), $P=0.012$
Chorion laeve	Goodness of fit ² : $P=0.590$ Coefficient for Relationship B: 0.617 (S.E.M.: 0.072), $P<0.001$ Coefficient for Relationship C: 0.021 (S.E.M.: 0.004), $P<0.001$

¹Analysis was performed with logarithmically transformed PGHS-2 mRNA relative abundance values.

²Based on Chi-square estimate with degree of freedom of 1.

Table 3 PGHS-1 and -2 mRNA and PGHS-2 hnRNA levels¹ in the gestational age groups

	ENL (10–19 weeks, $n=19$)	PNL (28–36 weeks, $n=20$)	TNL (37–41 weeks, $n=27$)
Amnion			
PGHS-2 mRNA	0.00563 (a) [0.000702–0.296]	0.0595 (b) [0.00714–1.352]	0.0531 (b) [0.0131–0.248]
PGHS-2 hnRNA	0.00249 (a) [0.000266–0.0434]	0.0153 (b) [0.00139–0.180]	0.0180 (b) [0.00591–0.118]
PGHS-1 mRNA	0.0114 (a) [0.000582–0.848]	0.00215 (ab) [0.000485–0.0571]	0.00108 (b) [0.000157–0.00645]
Chorion			
PGHS-2 mRNA	0.00297 (a) [0.000827–0.0792]	0.0254 (b) [0.00183–0.217]	0.0145 (b) [0.00231–0.0807]
PGHS-2 hnRNA	0.00133 (a) [0.000125–0.186]	0.00318 (a) [0.000443–0.183]	0.00384 (a) [0.000522–0.0109]
PGHS-1 mRNA	0.0275 (a) [0.00389–0.643]	0.00182 (b) [0.000175–0.142]	0.000505 (b) [0.000144–0.00224]

¹Relative to β -actin mRNA abundance in the same tissues. Values are represented as median, range in parenthesis. Letters indicate significance level, determined by Kruskal–Wallis ANOVA, followed by the non-parametric Dunn's multiple comparison test for each RNA type; $P<0.05$, (a) vs (b). ENL, early gestation; PNL, preterm; TNL, term.

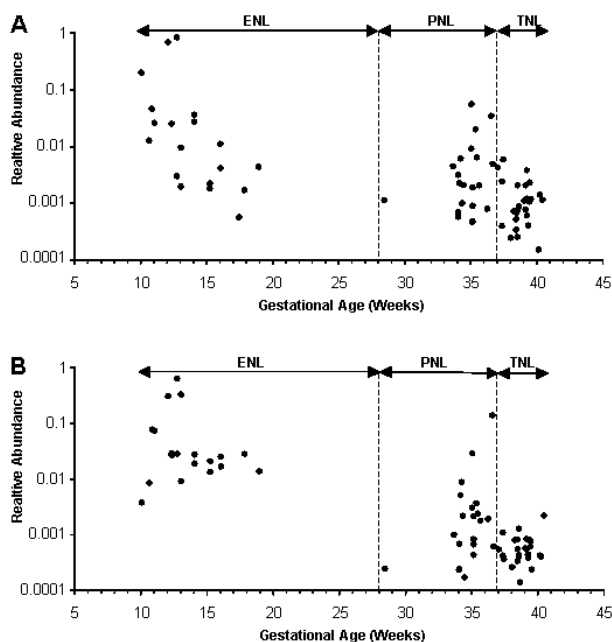

Figure 4 PGHS-1 mRNA relative abundance in the amnion (A) and the chorion laeve (B) during gestation. Note the logarithmic scale of the y axes. Gestational age groups (ENL, PNL and TNL) are also indicated.

Mijovic *et al.* 1998, 1999, Slater *et al.* 1999, Sadovsky *et al.* 2000). These investigations have demonstrated consistently that PGHS-2 mRNA, protein and activity levels increase in the amnion and the chorion between early gestation and term. Our principal aim in this study was to define the mechanism(s) responsible for this increase. We have determined PGHS-2 mRNA abundance, which is an established measure of PGHS-2 enzyme expression (Teixeira *et al.* 1994, Hirst *et al.* 1995, Mijovic *et al.* 1998, 1999), in the amnion and chorion between 10 and 41 weeks of pregnancy and assessed PGHS-2 gene activity in the same tissues. Using tissues from non-labouring women, we have avoided the effects

of the stress and trauma of labour, which are known to alter fetal membrane PG production (MacDonald & Casey 1993). It must be noted, though, that the PNL group included patients who underwent preterm elective Caesarean sections because of various indications, as described in the Methods. Some of these conditions are associated with an increased risk of preterm birth (pre-eclampsia), others are not (gestational diabetes) and others are close to being functionally normal (placenta praevia). These conditions and the associated treatments had no apparent influence on the distribution of data; therefore, we have evaluated the PNL patients in the study as a homogenous group. The regression analyses have shown that PGHS-2 gene activity is up-regulated in both fetal membranes with advancing pregnancy. The path analysis indicated, however, that increased gene activity did not account completely for the increase of PGHS-2 mRNA levels during gestation, suggesting that additional mechanism(s) participate in the regulation at the post-transcriptional level. PGHS-2 mRNA is highly stable in term amnion and chorion (Johnson *et al.* 2002, 2003); therefore, stabilisation in early or mid-gestation is a mechanism that may contribute post-transcriptionally to the elevation of PGHS-2 mRNA abundance with advancing pregnancy. A gestational age-dependent decrease in PGHS-2 mRNA degradation rate still needs to be shown to substantiate this possibility.

By comparing different gestational age groups, we have found that the major up-regulation of PGHS-2 mRNA levels occurs in both membranes at around 33–34 gestational weeks and possibly earlier, between 28 and 33 weeks of gestation. There was no further change in PGHS-2 levels at term (37–41 weeks). This time course has important physiological implications, because it indicates that a large increase in PGHS-2 expression occurs before term, well in advance of the period when labour normally starts. Furthermore, the spread of values in Figs 1B and 2B suggests that the PGHS-2 mRNA level remained relatively low in a subset of tissues at all stages of gestation. It is possible therefore that an up-regulation of PGHS-2 expression in the fetal membranes is not sufficient

Table 4 The relationship of PGHS-1 mRNA relative abundance¹ to gestational age² in the amnion and the chorion laeve

	Robust Regression estimates
Amnion	$n=66$; $F(1,64)=34.70$; $P>F=0.0000$ Coefficient: -0.0400 (95% confidence interval: $(-0.054)-(-0.026)$; $P< t =0.000$
Chorion laeve	$n=66$; $F(1,64)=188.76$; $P>F=0.0000$ Coefficient: -0.067 (95% confidence interval: $(-0.076)-(-0.059)$; $P< t =0.0000$

¹Relative to β -actin mRNA. ²Between 10 and 41 weeks of gestation. Predictor variable: gestational age in weeks; response variable: PGHS-1 mRNA relative abundance. Analysis was performed with logarithmically transformed data.

or obligatory to induce term labour. This may not be entirely surprising in view of the high PG-metabolising activity of the chorion laeve (Germain *et al.* 1994). The immediate trigger of human labour remains unclear, and events such as a decrease in chorionic PG-metabolism (Challis *et al.* 1999, Johnson *et al.* 2004), the stimulation of precursor supply (Liggins & Wilson 1989) may be considered as potential mechanisms stimulating uterotonic PG-release from the amnion and chorion immediately before term labour.

Comparing PGHS-2 gene activity and mRNA abundance in the gestational age groups suggested that the mechanisms responsible for the PGHS-2 mRNA up-regulation were different in the two fetal membranes. In the amnion, the increase in mRNA levels coincided with increased gene activity, while in the chorion, the increase in PGHS-2 mRNA abundance was not accompanied by significantly elevated gene transcription in the corresponding gestational age groups. This difference suggests that the post-transcriptional component of PGHS-2 mRNA up-regulation is more important in the chorion laeve than in the amnion.

Finally, our results indicate that PGHS-1 mRNA expression is relatively high in both fetal membranes in early pregnancy and decreases sharply with advancing gestational age. This time course is at variance with previous reports (Mijovic *et al.* 1998, 1999, Slater *et al.* 1999), which may be due to the high sensitivity and accuracy of the Q-RT-PCR technique compared with the semi-quantitative methods used in the former studies. The present data suggest that PGHS-1 generates the bulk of fetal membrane-derived PGs involved in pregnancy recognition and/or early maintenance, while PGs promoting parturition are produced mainly by PGHS-2. The segregation of early and late pregnancy functions of fetal membrane-derived PGs, therefore, may be performed by a corresponding shift in the expression of the two PGHS isoenzymes. A decrease in PGHS-1 mRNA levels with advancing gestation has been detected recently in the placenta, also using Q-RT-PCR, extending this possibility to placental PGHS-1 (Hirsch *et al.* 2005).

In summary, our data show that PGHS-2 mRNA expression increases in the two fetal membranes during the second half of pregnancy, reaching a maximum before term. PGHS-2 induction, apparently, is not sufficient to induce labour. Transcriptional and post-transcriptional mechanisms contribute to the stimulation, and our evidence suggests that the primary mechanism of up-regulation is transcriptional in the amnion and post-transcriptional in the chorion. Furthermore, there is a switch from PGHS-1 to PGHS-2 expression in the fetal membranes as pregnancy advances, corresponding to early and late pregnancy functions of intrauterine PGs. The regulatory factors and molecular pathways controlling these changes remain to be established.

Acknowledgments

Scholarship for R F J was provided by Research Higher degrees, University of Newcastle and contributed by Professors Roger Smith and David Smith.

Funding

Funding was provided by the National Health and Medical Research Council of Australia, The University of Newcastle and the Mothers and Babies Research Centre. Support was also provided from NSW Health through the Hunter Medical Research Institute. The authors declare that there is no conflict of interest that would prejudice the impartiality of this scientific work.

References

- Challis JR, Patel FA & Pomini F 1999 Prostaglandin dehydrogenase and the initiation of labor. *Journal of Perinatal Medicine* **27** 26–34.
- Challis JRG, Matthews SG, Gibb W & Lye SJ 2000 Endocrine and paracrine regulation of birth at term and preterm. *Endocrine Reviews* **21** 514–550.
- Elferink CJ & Reiners JJ Jr. 1996 Quantitative RT-PCR on CYP1A1 heterogeneous nuclear RNA: a surrogate for the in vitro transcription run-on assay. *Biotechniques* **20** 470–477.
- Freed KA, Aitken MA, Brennecke SP & Rice GE 1995 Prostaglandin G/H synthase-1 messenger RNA relative abundance in human amnion, choriodecidua and placenta before, during and after spontaneous-onset labour at term. *Gynecology and Obstetrics Investigations* **39** 73–78.
- Funk CD, Funk LB, Kennedy ME, Pong AS & Fitzgerald GA 1991 Human platelet/erythrocyte cell prostaglandin G/H synthase: cDNA cloning, expression, and gene chromosomal assignment. *FASEB Journal* **5** 2304–2312.
- Germain AM, Smith J, Casey ML & MacDonald PC 1994 Human fetal membrane contribution to the prevention of parturition: uterotonic degradation. *Journal of Clinical Endocrinology and Metabolism* **78** 463–470.
- Hirsch E, Goldstein M, Filipovich Y & Wang H 2005 Placental expression of enzymes regulating prostaglandin synthesis and degradation. *American Journal of Obstetrics and Gynecology* **192** 1836–1843.
- Hirst JJ, Teixeira FJ, Zakar T & Olson DM 1995 Prostaglandin endoperoxide-H synthase-1 and -2 messenger ribonucleic acid levels in human amnion with spontaneous labor onset. *Journal of Clinical Endocrinology and Metabolism* **80** 517–523.
- Johnson RF, Mitchell CM, Giles WB, Walters WA & Zakar T 2002 The in vivo control of prostaglandin H synthase-2 messenger ribonucleic acid expression in the human amnion at parturition. *Journal of Clinical Endocrinology and Metabolism* **87** 2816–2823.
- Johnson RF, Mitchell CM, Giles WB, Walters WA & Zakar T 2003 The control of prostaglandin endoperoxide H-Synthase-2 expression in the human chorion laeve at term. *Journal of the Society for Gynecological Investigations* **10** 222–230.
- Johnson RF, Mitchell CM, Clifton V & Zakar T 2004 Regulation of 15-Hydroxyprostaglandin Dehydrogenase (PGDH) Gene activity, messenger ribonucleic acid processing, and protein abundance in the human chorion in late gestation and labor. *Journal of Clinical Endocrinology and Metabolism* **89** 5639–5648.
- Lala PK 1989 Similarities between immunoregulation in pregnancy and in malignancy: the role of prostaglandin E2. *American Journal of Reproduction and Immunology* **20** 147–152.

- Liggins GC & Wilson T 1989 Phospholipases in the control of human parturition. *American Journal of Perinatology* **6** 153–158.
- MacDonald PC & Casey ML 1993 The accumulation of prostaglandins (PG) in amniotic fluid is an aftereffect of labor and not indicative of a role for PGE₂ or PGF₂ alpha in the initiation of human parturition. *Journal of Clinical Endocrinology and Metabolism* **76** 1332–1339.
- Mijovic JE, Zakar T, Nairn TK & Olson DM 1997 Prostaglandin-endoperoxide H synthase-2 expression and activity increases with term labor in human chorion. *American Journal of Physiology* **272** E832–E840.
- Mijovic JE, Zakar T, Nairn TK & Olson DM 1998 Prostaglandin endoperoxide H synthase (PGHS) activity and PGHS-1 and -2 messenger ribonucleic acid abundance in human chorion throughout gestation and with preterm labor. *Journal of Clinical Endocrinology and Metabolism* **83** 1358–1367.
- Mijovic JE, Zakar T, Angelova J & Olson DM 1999 Prostaglandin endoperoxide H synthase mRNA expression in the human amnion and decidua during pregnancy and in the amnion at preterm labour. *Molecular Human Reproduction* **5** 182–187.
- Mitchell BF & Powell WA 1984 Progesterone production by human fetal membranes: an in vitro incubation system for studying hormone production and metabolism. *American Journal of Obstetrics and Gynecology* **148** 303–309.
- Norwitz ER, Schust DJ & Fisher SJ 2001 Implantation and the survival of early pregnancy. *New England Journal of Medicine* **345** 1400–1408.
- Powell WA, Mitchell BF & Challis JR 1986 Effects of steroids on progesterone output by explants of human chorion. *Gynecology and Obstetrics Investigations* **22** 64–72.
- Rowe K 2002 The measurement of latent and composite variables from multiple items or indicators: Applications in performance indicator systems. In *Background paper to keynote address presented at the RMIT Statistics Seminar Series, October 11, 2002*, pp 1–23. Camberwell, Victoria, Australia: Australian Council for Educational Research; available at: <http://www.acer.edu.au/research/programs/documents/measurementofcompositevariables.pdf>.
- Sadowsky Y, Nelson DM, Muglia LJ, Gross GA, Harris KC, Koki A, Masferrer JL & Olson LM 2000 Effective diminution of amniotic prostaglandin production by selective inhibitors of cyclooxygenase type 2. *American Journal of Obstetrics and Gynecology* **182** 370–376.
- Slater D, Berger L, Newton R, Moore G & Bennett P 1994 The relative abundance of type 1 to type 2 cyclo-oxygenase mRNA in human amnion at term. *Biochemical and Biophysical Research Communications* **198** 304–308.
- Slater D, Allport V & Bennett P 1998 Changes in the expression of the type-2 but not the type-1 cyclo-oxygenase enzyme in chorion-decidua with the onset of labour. *British Journal of Obstetrics and Gynaecology* **105** 745–748.
- Slater D, Dennes W, Sawdy R, Allport V & Bennett P 1999 Expression of cyclo-oxygenase types-1 and -2 in human fetal membranes throughout pregnancy. *Journal of Molecular Endocrinology* **22** 125–130.
- Slater DM, Berger LC, Newton R, Moore GE & Bennett PR 1995 Expression of cyclooxygenase types 1 and 2 in human fetal membranes at term. *American Journal of Obstetrics and Gynecology* **172** 77–82.
- Smith WL, DeWitt DL & Garavito RM 2000 Cyclooxygenases: structural, cellular, and molecular biology. *Annual Reviews in Biochemistry* **69** 145–182.
- Teixeira FJ, Zakar T, Hirst JJ, Guo F, Sadowsky DW, Machin G, Demianczuk N, Resch B & Olson DM 1994 Prostaglandin endoperoxide-H synthase (PGHS) activity and immunoreactive PGHS-1 and PGHS-2 levels in human amnion throughout gestation, at term, and during labor. *Journal of Clinical Endocrinology and Metabolism* **78** 1396–1402.
- Trautman MS, Edwin SS, Collmer D, Dudley DJ, Simmons D & Mitchell MD 1996 Prostaglandin H synthase-2 in human gestational tissues: regulation in amnion. *Placenta* **17** 239–245.

Received 7 December 2005

Accepted 12 December 2005